

## Sunday School @ 9:45 am Sunday Mornings

(In-Person or via Zoom)

## Zion Pre-School Bulletin

April 14, 2022 (Year C) \* Maundy Thursday (Ages 3+)

To participate virtually, join us at <https://zoom.us/join> or by calling 301.715.8592, and when prompted, enter Meeting ID: **865 7471 1577** and Passcode: **YouthSS**. For more information: Contact Kim Ridenour at [miskim@myactv.net](mailto:miskim@myactv.net) or the Church Office at 301.739.7244 or visit <https://zionreformed.church/children>.

### Worship @ 11 am Sunday Mornings

Virtual Worship available at <https://zionreformed.church/worshiplive>



**Hearing God's Word:** Today is a special day, in fact this entire week is a special week. We call this week Holy Week. It is the week when we remember all of the events of Jesus' final week. Today is Maundy Thursday or Holy Thursday and is the day that we commemorate [honor or pay tribute to] the Last Supper and Jesus washing the Disciples' feet. We are celebrating this occasion today with a meal known as the Seder Meal. It is the meal which Jesus and the disciples would have sat down to celebrate as Jewish people during Passover [a Jewish festival or holiday that celebrates Jewish people being freed from slavery in Egypt, more about that in our Children's Moment]. Our scripture lesson comes from Luke 22:14-19. You can for today in Luke 22:14-71.



### Institution of the Lord's Supper

Int'l Children's Bible® Copyright© 1986, 1988, 1999, 2015 by Thomas Nelson. Used by permission.

<sup>14</sup> When the time came, Jesus and the apostles were sitting at the table. <sup>15</sup> He said to them, "I wanted very much to eat this Passover meal with you before I die. <sup>16</sup> I will never eat another Passover meal until it is given its true meaning in the kingdom of God."



<sup>17</sup> Then Jesus took a cup. He gave thanks to God for it and said, "Take this cup and give it to everyone here. <sup>18</sup> I will not drink again from the fruit of the vine until God's kingdom comes."

<sup>19</sup> Then Jesus took some bread. He thanked God for it, broke it, and gave it to the apostles. Then Jesus said, "This bread is my body that I am giving for you. Do this to remember me." <sup>20</sup> In the same way, after supper, Jesus took the cup and said, "This cup shows the new agreement that God makes with his people. This new agreement begins with my blood which is poured out for you."

*Recommended Additional Reading:*

*The complete account of the Lord's Supper in Luke 2:7-23*

**The Hours Before Jesus' Death**

Jesus ate a special meal with His disciples. It was Passover.

Trace the letters.



**Passover**

Jesus knew that the disciple who would betray Him was sitting at the table.

Connect the dots.

1 2 3 4 5 6 7 8 9 10 11 12 13 14 15

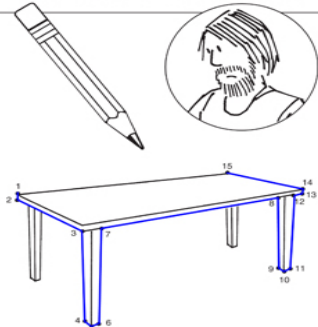

Jesus shared bread and wine with His disciples. It was to remember His body and blood.

Match the shapes.

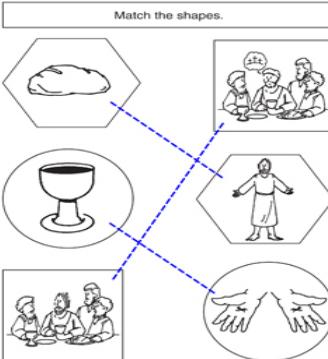

The disciples wondered who it was.

Count the disciples. Trace the numbers.



## Children's Moment: Origins of Communion



Do you like to be active? Yes? Being active means we have to do something very important—can you think of what that might be? That's right, we must take time to eat FOOD! Our bodies need hydration and fuel. We need healthy food to nourish us and give us strength to do what we want to do. But did you know that we need spiritual food, too? Just as food provides physical energy, we need something to give us spiritual nourishment. And there's something that we do here in our church service every week that reminds us of how we receive that spiritual food. Do you know what it might be? Yes, we celebrate Holy Communion every week in remembrance!

Today, for Maundy Thursday we celebrate the Lord's Supper (Holy Communion), remembering the origins of our Christian tradition of Communion. Communion is a time set aside to remember. During Holy Communion we usually receive some (bread/cracker/wafer) and a small cup with juice or wine, which we call Communion elements. These elements remind us that Jesus gave His life for us. But do you know where this tradition comes from? Why do we do it during our worship service? Who came up with the idea? Well, it has a pretty solid origin story...

The night before Jesus died on the cross, He met with His disciples for a special meal during Passover known as the Seder Meal. The tradition of Passover celebrations began in Egypt when God told Moses that deliverance was coming the next day so it had been around for a while even in Jesus' time on earth as a human. The Passover meal was familiar to God's people. It reminded them of the night in which God sent the destroyer into Egypt and killed the oldest son in every household, except those houses which had the blood of the lamb spread over the door posts. [Read Exodus 12:7,13] The blood was a sign that the destroyer would see and pass over that house and spare the life of the oldest son within. God told the children of Israel to keep the feast of Passover as a memorial of their deliverance from being slaves for the Egyptians. This day was to the Israelites as our Independence Day is for Americans. It was the day they were set free.

## The disciples wondered who it was.

Count the disciples. Trace the numbers.

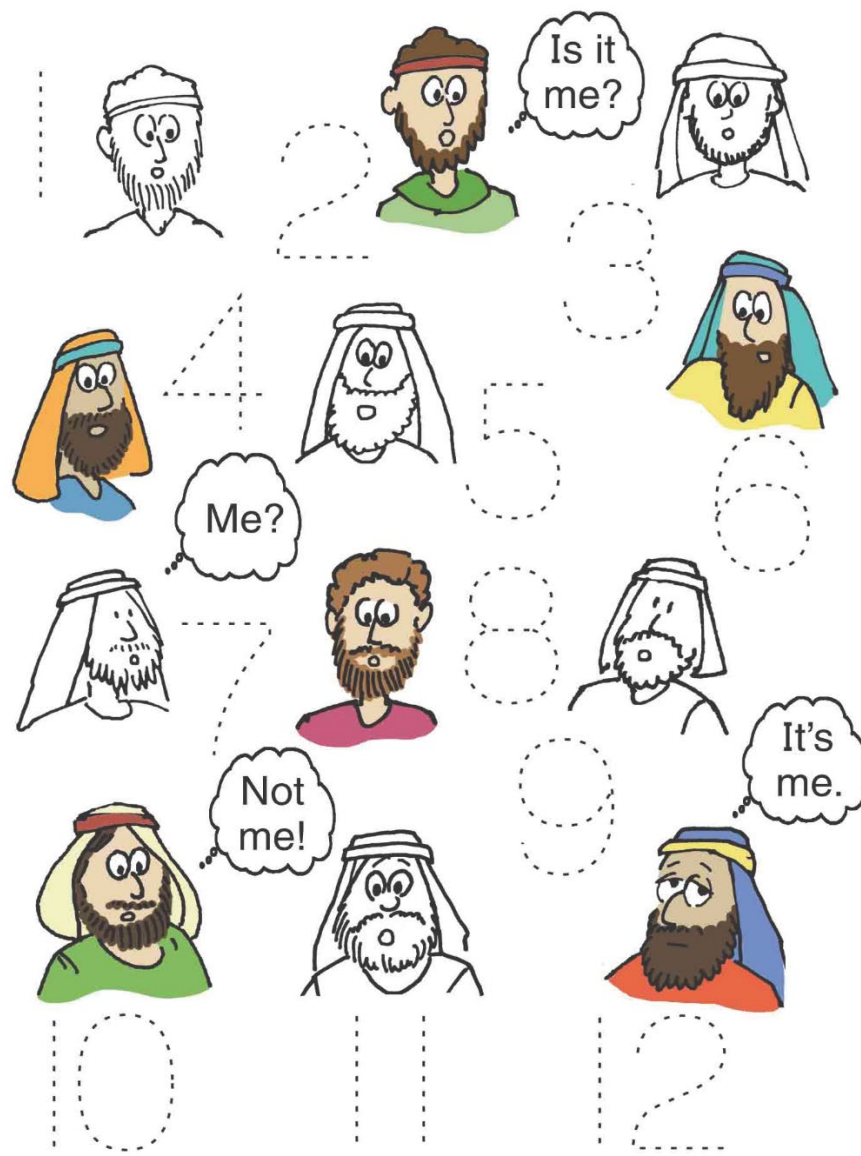

# Jesus knew that the disciple who would betray Him was sitting at the table.

Connect the dots.

1 2 3 4 5 6 7 8 9 10 11 12 13 14 15

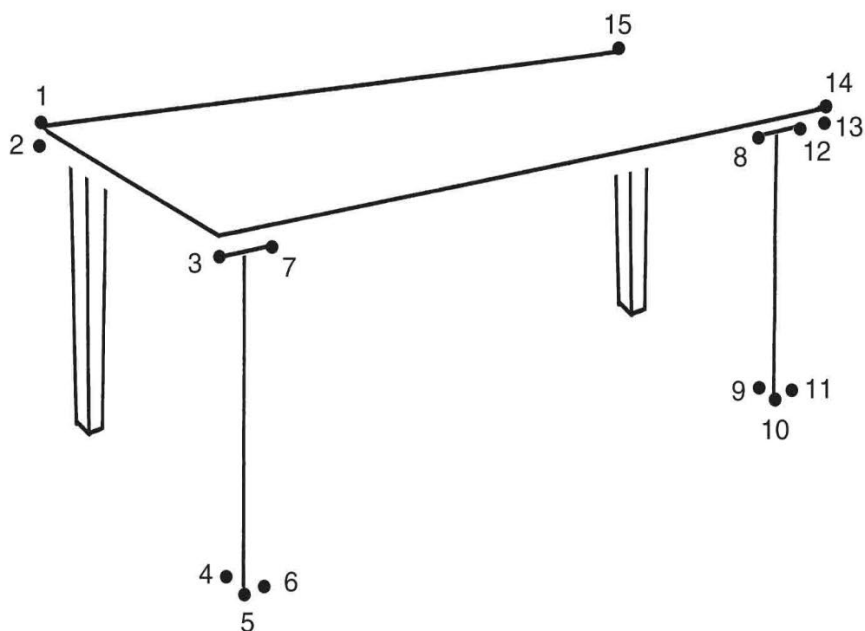
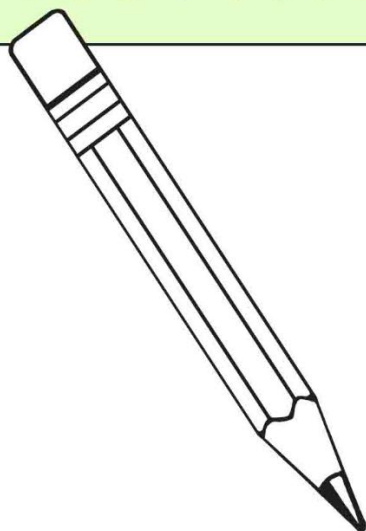

But Jesus knew that this seder meal was no ordinary seder meal, but the last time He would get to have dinner with his disciples before His suffering and there were some important things that He did and said while they were gathered together. Jesus wanted them to know how much He loved them, and He commanded them to love others. He washed their feet to show that He was a servant, and expected them to serve one another.

During the meal, Jesus took bread to share with those at the table. When He broke the bread, He told the disciples "this is my body, broken for you. Do this in remembrance of me." And He passed around the wine and said "this is my blood, poured out for you." The disciples may not have understood it, but Jesus was telling them that He was doing something new and amazing. Before Jesus, people of God were required to make animal sacrifices for their sins. Jesus was communicating that His blood was going to cover sin once and for all. And as He passed around the bread and wine, He told His friends to remember Him and what He did, and to be inspired when they remembered to follow him by being servants to others in love also. He gave up His life so that we may love God and others. He covered our sins with His blood.

Though Holy Communion is rooted in the seder meal of Passover, the meal took on new meaning for the disciples after Jesus rose on Easter morning. Now, when we receive or watch the celebration of the Lord's Supper (Communion), we remember. We remember what Jesus did and still does for us. We remember that our sins are covered by His blood. We remember that we have responsibility to love and serve others with out judgment or exception as Christ loved and served us. This is a blessed and beautiful thing that we have! Jesus wants us to know that He is with us always. He loves us and promises to take care of us. That is how the Passover meal became known as the Lord's Supper. Jesus commanded us: this do in remembrance of me. It has continued to this day in the churches for us to remember the sacrifice Jesus made for our sins.

Adapted from Children's Sermon dtd 3 Aug 2013 by Jim Kerlin from [childrensermons.com](http://childrensermons.com) and Children's Sermon dtd 2 Apr 2022 by Kristin Schmidt from [ministry-to-children.com](http://ministry-to-children.com).

**Let Us Pray:** Dear God, Thank you for sending your son, Jesus, the ultimate sacrifice for our sins and the perfect example of loving all people with exception. Help us to remember Christ's presence and share your love with others around us. Thank you for loving us We love you, God! In Christ's name we pray, Amen!

Jesus shared bread and wine with His disciples. It was to remember His body and blood.

## The Hours Before Jesus' Death

Jesus ate a special meal with His disciples. It was Passover.

Trace the letters.



Passover

Enter your **SECRET CODE** to unlock games @ [games.childrensbulletins.com](http://games.childrensbulletins.com)

**SECRET CODE**  
**JSYQ03**

Match the shapes.

